

Modeling Arrival Flight Traffic Using Arena®

Charles J. Kim, Daniel A. Akinbodunse, and Chibuikwe Nwakamma
Department of Electrical and Computer Engineering
Howard University
Washington, DC 20059
ckim@howard.edu

Abstract- An arrival flight traffic model is presented to simulate time-varying arrivals via airport arrival fixes to runway. The underlying simulation was developed to support an analysis of airborne holding at airport meter fixes, based on changes in arrival capacity and operating procedures of the destination airport. A principal challenge was developing a modeling approach for aircraft arrivals, where it is understood that the arrival rate varies by time-of-day, day-of-the-week and season. Analysis of inter-arrival time of flights during a selected peak arrival period, of the first seven months in 2004 at George Bush Intercontinental Airport (IAH) was performed on data obtained from Aviation System Performance Metrics (ASPM) and Federal Aviation Administration (FAA) database. *Arena*® input analyzer was used to generate mathematical expressions, based on the inter-arrival time distribution of aircraft extracted from the database, for the “*Create module*”. In the simulation, probable arrivals were generated to mimic flight transitions from extreme arc to specific runways at IAH. The simulation results gave an estimate of the number of flights, with their transition time between the arcs, which arrives at IAH within a select peak period.

Keywords: Air Traffic Control, Traffic Management Advisor (TMA), Modeling and Simulation, *Arena*®

I. INTRODUCTION

The gate-to-gate operation of air traffic consists of three navigation flight phases: departure, en route, and arrival. It is important to note that each aircraft is permitted flight airspace according to individual flight plan. All arriving aircraft must pass through a meter fix before final approach to the runway. An automation supportive tool, i.e. the Traffic Management Advisor (TMA) begins to monitor flights as soon as they are about 200 nautical miles away from the destination airport.

TMA is a support tool and has time-based strategic planning capabilities which provide the Traffic Management Coordinators (TMC) and Center controllers the ability to effectively manage the capacity of a demand impacted airport. TMA comprises of trajectory prediction, traffic visualization, controller arrival flight sequencing, constraint-based runway scheduling, and

delay advisories. Houston Center (ZHU) is one of the current Air Route Traffic Control Centers (ARTCC) to deploy TMA for sequencing flight arrivals to IAH [1, 2].

TMA helps to effectively and efficiently sequence arrival traffic via the Terminal Radar Approach Control (TRACON) airspace to the destination airport terminal space without violating current airport capacity and safety. Besides scheduling and allocating flights to destination airports, TMA also provides graphical views that enhances situational awareness to TMC and Center Controllers’ of impending peak arrival periods via the rush alert window [3].

During peak arrival periods, current airport arrival rate (AAR) may be violated and not many flights would be given landing clearance. Thus, aircraft would have to “hold” until they receive landing clearance from local Air Traffic Control Tower (ATCT). The holding period introduces flight delay and costly fuel expenditure for the airline. As flights arrive during a particular holding period, the queue of flights awaiting landing clearance begins to grow. Each arrival flight takes turn, in a First-In-First-Out (FIFO) manner, to access a specific runway depending on the geographical position of the particular flight. If arrival flights enter the terminal airspace of their destination airport without an available runway for landing, they will observe a cycling process around the local air space until landing clearance is issued by the ATCT.

However, every arrival that meets an incumbent cycling aircraft would have to join the cycling process, which gradually grows until a queue of aircraft awaiting landing authorization is generated. Since aircraft consume more fuel at lower altitude, TMA serves as a means of sequencing flight arrival via time-based metering so that the AAR of the destination airport is not exceeded and airline fuel overheads is minimized. However, most airline industries have lost huge amount of money to jet fuel as a result of these delays, especially at the meter fixes. Since, holding takes place at lower altitude, aircraft tend to consume more jet fuel, which is bad business for airline operations.

For instance, in 1991, 23 major airports experienced more than 20,000-hrs of annual aircraft flight delays. If an average airline operating cost of 1-hr delay is \$1600, these imply an annual loss of \$740 million for 23 airports

altogether [4]. Fortunately, TMA is able to predict when a rush would occur and then computes new Scheduled Time of Arrivals (STA) for individual flights from their filed flight plan, i.e. Estimated Time of Arrival (ETA) at the destination airport. TMA then displays the new STA which arriving aircraft must follow to avert a rush. Based on TMA's advisories, TMC and traffic controllers will instruct aircrafts to reduce speed, re-route, or hold at higher altitude rather than at the meter fix airspace (lower altitude). This procedure is expected to effectively reduce airline fuel expenditure, unnecessary delay at meter fixes (lower altitude), and traffic controllers' work load.

The focus of the research is to analyze the time spent by arrival traffic as they transverse the National Airspace System (NAS) through the Descent, Approach and Landing phases directly from recorded flight data of a selected demand impacted airport, i.e. IAH. Then, a model is built and simulated to back-up and extend the analysis performed using IAH 2004 data.

This paper first presents a brief description of George Bush intercontinental airport layout. This will be followed by a discussion and analysis of time spent by arrival aircraft between airspace arcs (rings), i.e. Extreme Arc (EA) to Outer Arc (OA), Outer Arc (OA) to Inner Arc (IA), Inner Arc (IA) to Meter Arc (MA), and Meter Arc (MA) to Runway (RW). Next, we will give a brief

description of the arrival traffic model wed developed using Arena and compare the simulation results with those computed directly from the recorded IAH 2004 data that were obtained from FAA and ASPM database. Finally, we conclude the paper and suggest future works.

II. IAH LAYOUT AND STATUS

A. Air Spaces around IAH

George Bush Intercontinental (IAH) is the 8th busiest airport in the U.S. in terms of total passenger enplanements and the 11th busiest in the world. It was estimated that IAH airport had a regional economic impact of more than \$8 billion annually and created more than 90,000 jobs during 2003. Moreover, in 2004, IAH was ranked 2nd among U.S. airports for scheduled non-stop domestic and international destinations, and it increased international destinations by 14 in the first six months of operation.

IAH airport system provides service to 184 destinations (64 being international destinations in 28 countries). IAH is one of the Operational Evolutional Plan (OEP) 35 airports which are highly recognized as United States' demand impacted airports.

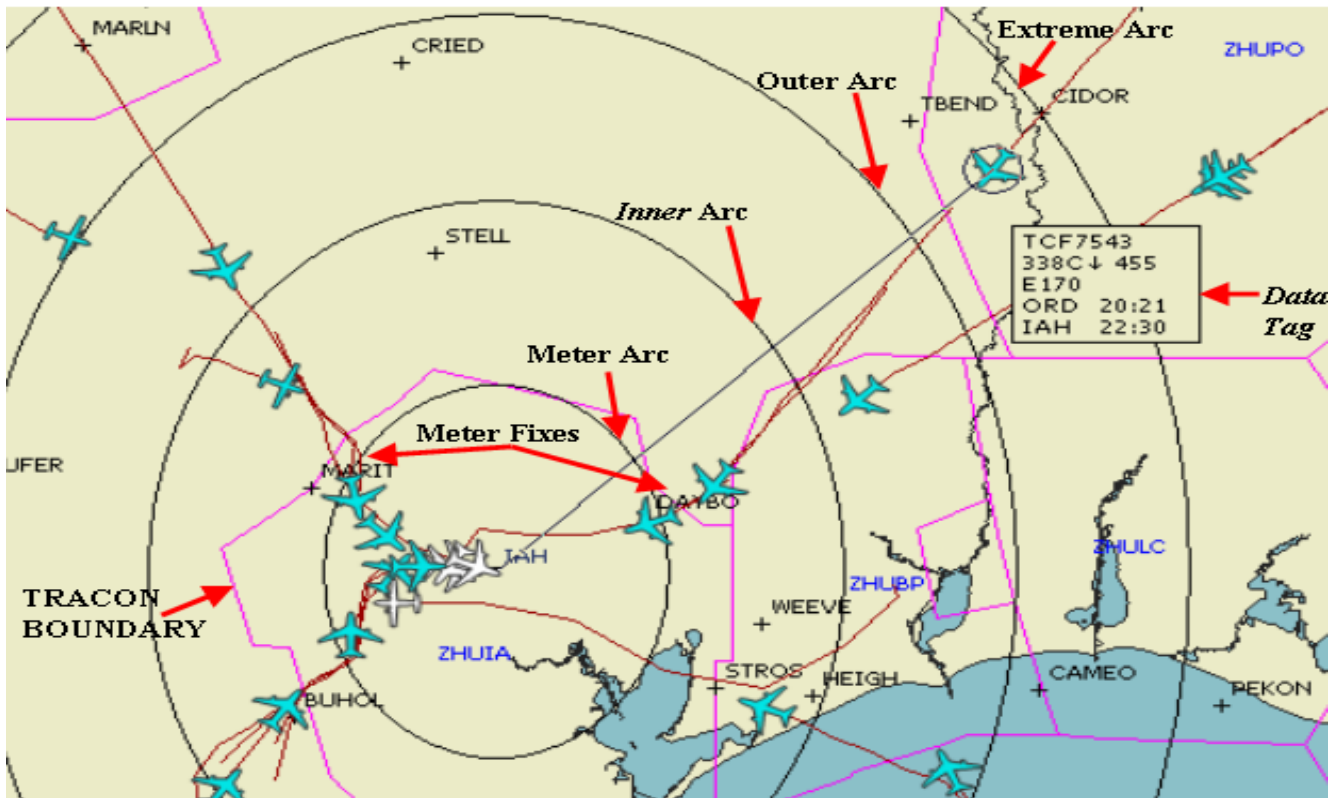

Figure 1. George Bush Intercontinental Airport Approach Paths, Arcs, and Fixes

IAH has 2 basic peak arrival periods: 0700 to 1300 and 1600 to 2100 local time in minute [5]. Also, the days of the week for which IAH often observes peak arrivals include: Monday mornings, Thursday afternoons, Friday, Saturday mornings and Sunday. Our analysis will span an hour rush period, which ranges from 1857 to 1957 local time in minute, of the first seven months in 2004.

As illustrated in Figure 1, IAH has 4 major meter fixes (geographically located around IAH) namely: MARIT, DAYBO, STROS, and BUHOL. They represent the gate way through which every IAH arrival flight must pass before final approach on runway. The figure was obtained from a flight monitoring tool and it also shows the geographical positioning of the arcs around IAH.

B. Passenger Service Records at IAH

The U.S. Department of Transportation's On-Time Performance Report released in August 2005 which reviewed the United State's top 33 major airport for on-time arrival and departure performances through June 2005, ranked IAH as the nation's top performer in all four rating categories: on-time departures and arrivals in June 2005, and on-time arrivals departures year-to-date through the same month [6].

In addition, IAH served a record number of passengers in 2004. Table I provides a statistical analysis of the number of passengers that departed (enplaned) and arrived (deplaned) at IAH from 2001 to 2004. We see that, in 2004, IAH recorded a 6.44%, 7.32% and 5.1% increase compared with 2003, 2002, and 2001, respectively.

Table I. IAH Passenger Departure and Arrival Statistics

PASSENGERS' STATUS	2001	2002	2003	2004
Enplaned (int'l & domestic)	17,437,784	16,897,821	17,003,336	18,254,237
Deplaned (int'l & domestic)	17,365,796	17,007,026	17,148,006	18,251,879
Total (int'l & domestic)	34,803,580	33,904,847	34,151,342	36,506,116

C. Runways at IAH

There was a new runway construction following the FAA's capacity enhancement plan. In November 2003, a new runway, 8L/26R, was constructed parallel to the former runway, 8R/26L, at about 4,500 feet away. Runway 8L/26R is 9,000 feet long and 150 feet wide and it includes high-speed exits to the parallel taxiway to ensure speedy flight operations. The new runway is

IAH's 5th runway and 3rd parallel Category III runway, permitting triple independent simultaneous all-weather flight operations and it is the 1st runway at IAH to utilize LED Taxiway Edge Light Fixtures. Currently, IAH is one of only 3 airports in the U.S. that has the ability to land three airplanes at the same time in the lowest visibility conditions. Since the addition of a new runway at IAH, the airport has recorded reduced flight delays, reduced airborne traffic jams, especially during bad weather, reduced aircraft ground delays, resulting in lower total emissions, and registered 108 arrival operations per hour under normal visibility conditions.

In addition to the construction of a new runway at IAH, Runway 15R/33L was extended and widened to 10,000 feet so that it could accommodate arrivals and departures of commercial jets. Figure 2 shows a pictorial view of IAH runway configuration.



Figure 2. IAH Airport Runway Layouts

When Runway 8L/26R was opened in November 2003, the existing Runway 8R/26L was closed for resurfacing until July 2004. Also, work was carried-out on Runway 9/27 and its Taxiways during the same period. Thus, as a result of all the simultaneous activities and changes, we were only able to analyze flight arrivals on runways 8L/26R, 9/27, 15L/33R, and 15R/33L.

Lastly, we considered the four airspace arcs (rings) outside of IAH as shown in Figure 3. These arcs include:

1. Extreme Arc (EA) at 200 nautical miles to IAH

2. Outer Arc (OA) at 160 nautical miles to IAH

3. Inner Arc (IA) at 100 nautical miles to IAH

4. Meter Arc (MA) at 40 nautical miles to IAH

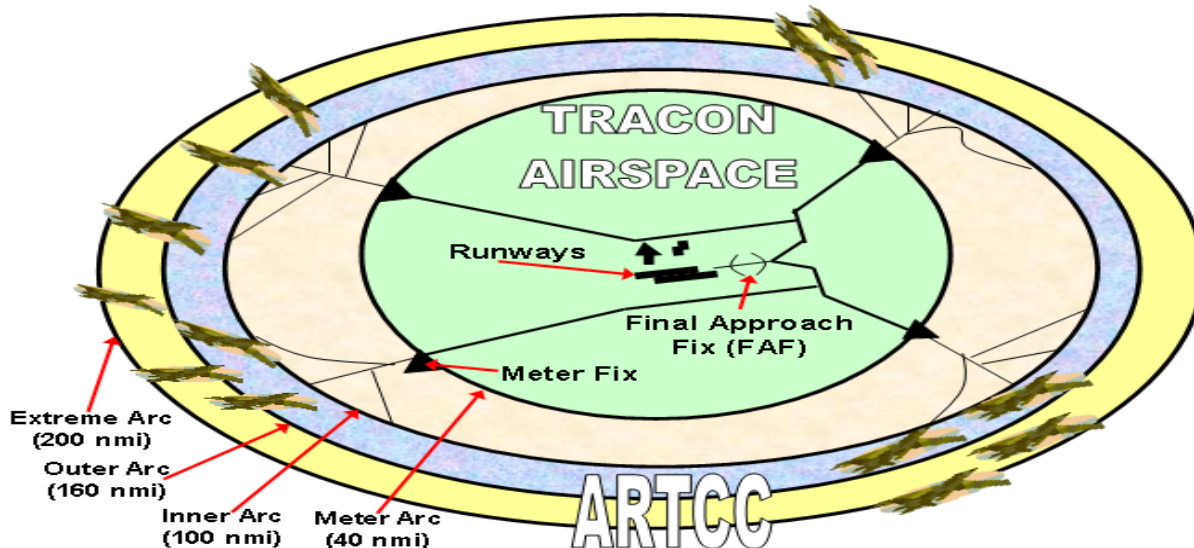

Figure 3. Geographical Position of Airspace Arcs (Rings)

III. ARRIVAL TRAFFIC AT IAH

When an aircraft, scheduled to arrive at IAH, comes within a couple of hundred miles of its destination, the ARTCC will direct it to begin a descent to a specified lower altitude. The TRACON management team coordinates a smooth flow of arrivals into the TRACON airspace. The Center controller maintains a safe

separation of aircraft while directing each aircraft from a higher altitude to a lower altitude.

We analyzed the cumulative flight time of all arrival aircrafts between the arcs, and the number of flights that landed at IAH during a selected rush hour period for the first seven months in 2004. Furthermore, we refined our analysis and looked into a short time window of a selected rush hour period for the first seven months in 2004. Table II tabulates the result of the analyses.

Table II. Direct Data Analysis of 2004 IAH Arrival Traffic

Month	EA - OA (min)	OA - IA (min)	IA - MA (min)	MA - RW (min)	No. Of Arrivals
JAN	11510.8	18856.8	21215.4	30806.5	2067
FEB	10679.0	17504.2	19832.1	29599.8	1897
MAR	11656.3	19384.7	21460.5	33777.5	2121
APR	10831.0	17965.6	20451.4	31794.1	2009
MAY	10620.7	17880.6	20429.8	32099.2	2037
JUN	9570.6	16128.2	18136.1	26380.4	1803
JUL	11323.1	18348.1	21186.4	31976.9	2189

Month	RWY_8L_26R	RWY_9_27	RWY_15L_33R	RWY_15R_33L
JAN	983	1074	2	8
FEB	931	965	0	1
MAR	1063	1056	0	2
APR	1032	967	2	8
MAY	984	1050	1	2
JUN	848	942	4	9
JUL	1145	1036	6	2

The upper table of Table II shows the cumulative sum of peak monthly arrivals, EA to OA, OA to IA, IA to MA, and MA to RW transition time (minutes) in 60 min time intervals corresponding to rush hour period 1857 to 1957 local time in minute. The lower table displayed the number of monthly arrivals at each runway. The procedure required for building a model and simulating the model in aircraft holding, time spent traveling between arcs, and actual number of flights that landed during the period of observation is discussed next.

IV. ARRIVAL TRAFFIC MODELING AND SIMULATION

The *Arena* modeling software tool, manufactured by Rockwell Automation, can be implemented for simulating most intricate problems by mimicking the vital characteristics of real life systems, by using its basic modules called building blocks. To build a model, we need to open a new model window and place the required modules on the screen. After naming individual modules, the model window shows a model similar to Figure 4.

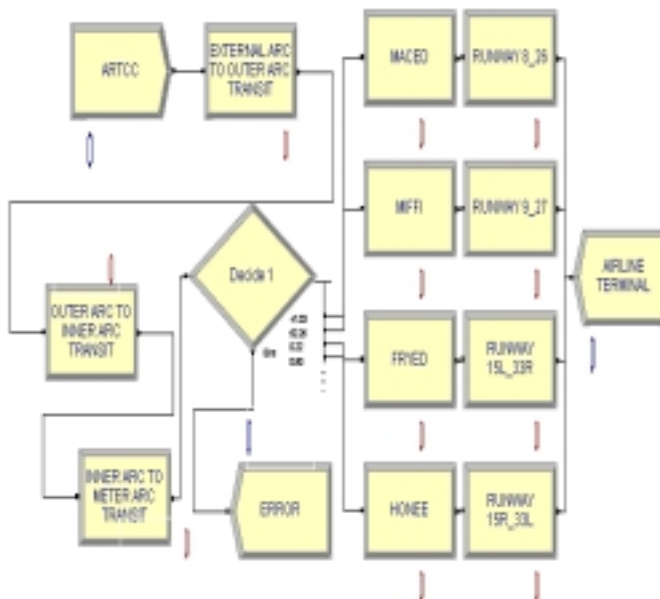

Figure 4. Arena Arrival Traffic Model

The "ARTCC" module simulates flight arrivals at the EA. The inter-arrival time of all flights that arrived at IAH during the chosen rush hour period are exported from 2004 IAH database to the Input Analyzer of Arena, which will determine the best arrival distribution that closely defines the inter-arrival characteristics of flights at the EA (See Figure 5). In addition, the Input Analyzer also generates a mathematical expression, which will be used as an input for the "Create module." For instance, the expression generated for the figure below is

$$-0.01 + \text{EXPO}(3.72)$$

This expression defines an exponential distribution of mean equal to 3.72, shifted to the left by 0.01. The same procedure is repeated for the other modules. The decision module "Decide 1" will simulate the sequencing of flights' arriving IAH from different geographical locations via the meter fixes at the Meter Arc. Also, this ensures that flights that have been scheduled to land at a particular runway go through the specific meter fix that is geographically located in space for aircraft to begin final approach to a runway.

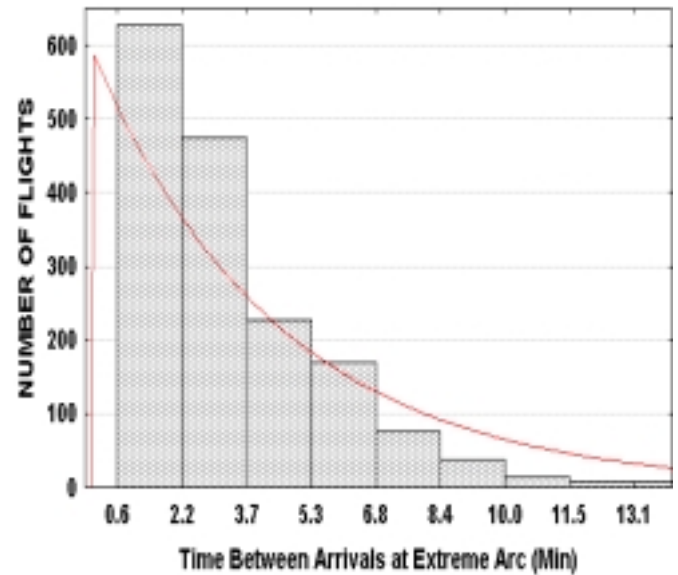

Figure 5. Extreme Arc Inter-Arrival Distribution for Selected Peak Time in January 2004

After the necessary mathematical expressions have been generated and entered into respective modules as in Figure 4, the model is then simulated for all peak period 1857 to 1957 local time in minute for each of the selected month. The simulation was run for a cumulative inter-arrival time at the EA, for 20,000 replications. This time was chosen so that all flights that cross the EA are considered in the final simulation result. The same procedure is applied to the remaining six months of 2004.

Table III displays the simulation results for comparison analysis between the simulated results and the results obtained by computing the delays and hold of arrival traffic directly from the database.

Comparing Table II and Table III, we see that the differences between the direct data analysis and the simulation results are not very pronounced. For instance, we observed that March and May had somewhat closest to the actual data analysis.

Table III. Simulation Result from Arena Software tool

Month	EA - OA (min)	OA - IA (min)	IA - MA (min)	MA - RW (min)	No. Of Arrivals
JAN	11512.0	18823.0	21265.0	30666.3	2056.9
FEB	10941.0	17479.0	19778.0	14995.7	1888.1
MAR	11670.0	19374.0	21362.0	33684.2	2113.2
APR	10771.0	17946.0	20329.0	31670.6	2000.9
MAY	10643.0	16118.0	20218.0	32180.9	2030.4
JUN	9634.7	16247.0	17981.0	26231.7	1796.8
JUL	11289.0	18315.0	21029.0	31877.2	2180.2

MONTH	RWY_8L_26R	RWY_9_27	RWY_15L_33R	RWY_15R_33L
JAN	978.4	1068.6	2.1	7.8
FEB	926.8	960.4	0.0	0.9
MAR	1059.0	1052.2	0.0	1.9
APR	1028.0	963.0	2.0	8.0
MAY	981.0	1046.6	1.0	1.8
JUN	845.2	938.8	4.0	9.0
JUL	1140.6	1032.1	5.8	2.0

V. CONCLUSIONS AND FUTURE WORKS

The arrival traffic simulation at IAH, using Arena, presented in this paper was carried out on arrivals at the Extreme Arc, transit time between the arcs, and runways arrivals. Each simulation, with 20000 replications, generated the outputs that have close values to the direct data analysis output. The result of this paper presents a means of simulating various probable activities that could occur at IAH airport. Recommendations and future work include the following:

1. Further work needs to be done on the model so that it can capture the aircraft types from the actual flight database.
2. Fuel cost incurred by airline due to holding at the meter fixes need to be simulated so that one can predict expenditure of airline jet fuel.
3. This paper would become more interesting if aircraft departure from origination airport can be integrated into the model.
4. More simulation that would consider departure rate, en route congestion, and airport weather condition need to be considered, and
5. An integration of arrival control system and en-route control system needs to be studied so that a common linkage could be established between them, and could provide proper management and scheduling of arrival aircrafts to runways.

VI. ACKNOWLEDGMENT

We would like to acknowledge the Federal Aviation Administration (FAA) for their financial support

and its project manager, Kelvin Streety, for his technical support. We also give our thanks to the student workers in the Signals and Systems Laboratory at Howard University, Khalid Abubakar and Chimaobi Mbanaso for their help with data analysis. Also, we extend our gratitude to the reviewers of the paper for their thorough reviews and critical but valuable comments, which stimulated us to make a drastic change to the original paper.

VII. REFERENCES

- [1] Free Flight Program Office, "FFP1 Performance Metrics to Date: June 2003 Report," June 2003.
- [2] Free Flight Program Office, "FFP1 Performance Metrics to Date: December 2003 Report," December 2003.
- [3] Harry N. Swenson, et al., "Design and Operational Evaluation of the Traffic Management Advisor at the Fort Worth Air Route Traffic Control Center", Presented at *the 1st USA/Europe Air Traffic Management Research and Development Seminar*, Saclay, France, June 17 – 19, 1997.
- [4] Eugene P. Gilbo, "Optimizing Airport Capacity Utilization in Air traffic Flow Management Subject to Constraints at Arrival and Departure Fixes," *IEEE Transactions on Control Systems technology*, Vol. 5, No. 5, September 1997.
- [5] FAA & Air Traffic Organization, "Operational Performance Summary for Selected ATO Capacity and Efficiency Initiatives," Office of Operations Planning-Performance Analysis, July 2004
- [6] Houston Airport System 2000 to 2005: available at: <http://iah.houstonairportsystem.org/news/?id=170>