

A Study on the Characterization of the Incipient Failure Behavior of Insulators in Power Distribution Line

Charles J. Kim, *IEEE Member* Jeong Hoon Shin Myeong-Ho Yoo Gi Won Lee

Abstract: A feasibility study on the characterization of incipient insulator failure for distribution fault prediction is presented. In this study, real distribution data was collected and analyzed to isolate incipient failure signatures or parameters which were expected to show distinct behaviors before and after failure incident. Several signal analysis methods were applied to isolate the parameters and a new strategy of analysis, the event-date concept, was also applied to find a relationship between non-harmonic and high frequency signal activities and imminent insulator failures.

Keywords: Failure prediction, incipient fault, insulator, data analysis, predictive maintenance

I. INTRODUCTION

The failure of equipment in power distribution systems can have direct or indirect impact on the reliable delivery of electricity. Also, certain failures can result in loss of service. Hence, a strategic and well-organized method to predict distribution system equipment failures would be of great importance for maintaining a system reliable.

There is a great interest in the utility company for real-time and on-line approaches for detecting and locating incipient failure sources. If a device is the source of the fault, repair or replace of the device could be made or any required maintenance actions would be recommend [1].

When some distribution equipment begins to deteriorate, it is believed that intermittent incipient faults persist in the system from as little as several days to several months. Therefore, to secure highly reliable distribution system, it is essential to monitor distribution line and classify and discriminate the signatures of failure of the equipment before their actual breakdown or breakout[2]. In other words, Two most important things for failure prediction are to monitor the system on its gradual path from healthy to sick status and to detect the causes of the degradation.

In this study we collected and analyzed the real line signal under an assumption that equipments are undergoing a path to the failure and they generate characteristic signatures which indicate the status of the healthiness[3]. As the first phase of a long term research aiming for a total failure prediction system for power distribution line, the study was centered on the investigation of various parameters which may indicate a failure status and, thereby, foretell an imminent failure before its occurrence.

In the study, we could not isolate prediction parameters for insulator failure, however, we could find the possibility that continual daily increase of the variability of high-frequency and non-harmonic components may be used to warn the failure of insulators.

II. STATUS OF INCIPIENT FAILURE DETECTION

A variety of conditions can lead to supply interruptions during fair-weather conditions. One common cause of fair-weather interruptions for overhead feeders is broken or contaminated insulators and it occupies about 25% of the overall distribution failures[4]. Contaminants can build up around even a hairline crack in an insulator. These contaminants may have relatively high conductivity as compared to the normal surface of the insulator, especially when it is wet, providing an unintended path from the high voltage conductor to the insulator's metal pin. Habib et al. have monitored the leakage current with a toroidal coil placed on the string of insulators. This method requires a specialized toroid to be placed in series with the insulator[5].

Several studies have been made for monitoring the conditions of other various pieces of equipment such as circuit breaker, transformer, and underground power cables [6-9]. In particular, Hydro-Quebec has developed a predictive maintenance console on its Smart Station system to monitor such factors as transformer-oil purity, generator vibration, and breaker wear, allowing maintenance on an as-needed basis[10].

Recently, a project of distribution fault anticipator/locator is undergoing funded by EPRI with objects to reduce labor costs and crew time through faster identification of faults, and to decrease outages through detection of incipient faults[11]. According to the project's goal, it is directed to develop a new equipment, along with sensors to be scattered along the line, for prediction of incipient faults and momentary line contact (such as tree limb contact). However, a proven method or approach for incipient failure detection in distribution system is not yet available.

III. RESEARCH DIRECTION AND PHILOSOPHY

It is believed that the fair-weather faults are associated with degraded equipment (insulators, arresters, transformer insulation and bushings, etc.) and the gradual intrusion of tree limbs as they grow into the overhead power line. We believe that signals exist on an operating power system that will allow the early detection of incipient fault conditions.

It is highly desirable to locate a particular parameter that alters its behavior in a recognizable way during incipient fault conditions so that recognition of such an alteration constitutes a clear indication of an incipient condition. In this scenario, the characteristic behavior would manifest itself progressively during the incipient phase leading to an overcurrent fault condition.

In order to identify and then take advantage of these

characteristics, we investigated the behavior of equipments in the real feeder environment, instead of investigating in an isolated or controlled environment. Some characteristic behaviors found from the investigation would be compared before and after specific equipment's failure incident. If we would do this process long enough we could get a realistic and applicable failure prediction system in the future.

This methodology will greatly enhance the probability of determining useful parameters for incipient fault detection in electric power distribution systems. However, there is a concern regarding this research direction: the possibility or certainty of containing the signature of the failing equipments in the data we collect from the line. Hence, a proper and cautious data collection, retrieval, and analysis is the most critical part of the research. In this regard, we made our best efforts under constraint so that the recorded signals represent the most of the status of a distribution line in which equipments in healthy and incipient fault conditions are installed.

III. DISTRIBUTION DATA ACQUISITION

A. Preliminary Consideration

The sites for data recording were selected after reviewing the Korea Electric Power Co. (KEPCO)'s report on relay activity in 1994 and 1995 in which relatively active substations and feeders are identified. After considering other factors like easiness of the installation and management of the recording device, we selected two substations known to have had high frequency of fair-weather faults: Kongju substation and Osan substation. However, data recording was conducted on two feeders of typical 22.9 kV in Kongju substation only. During the data recording, weather information was not seriously considered.

B. Data Collection

We recorded distribution line signals (currents and voltages) on VHS video cassettes using a Racal V-Store 16 instrumentation recorder in FM (frequency modulation) signal electronics [12]. The Recording Interface of the set-up configuration in Figure 1 provides the interface between the line and the recording system. We used standard substation current and voltage transformers (CT's and PT's) to convert the distribution voltage of 22.9kV and high current signals to nominal 120-volt and 5-amp levels, respectively. The nominal levels of the signal were further reduced using smaller transformers.

The present work seeks to identify incipient fault current levels, which probably will have very small magnitudes in relation to load current levels. Also, the current is assumed to include high frequency signals. Hence, we conditioned the signal with filtering circuit. First, we effectively eliminated the dominant fundamental frequency. Then we high-passed the notched-out signal with cutoff frequency of approximately 2 kHz in order to filter out high frequency component. These

filtered signals were amplified with an amplification factor of approximately 60 dB (x 1000).

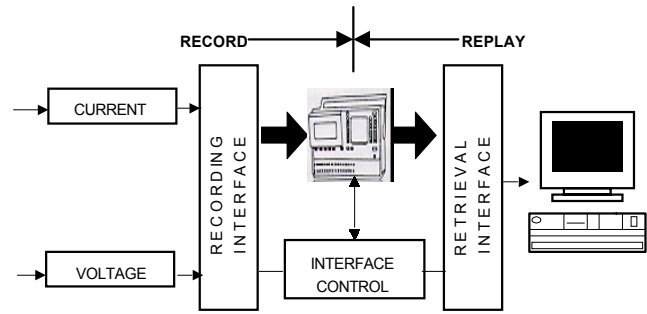

Figure 1. Configuration of the recording system.

For recording timing, we configured the control interface in Figure 1 so that the recording device automatically records twice per day, a one-minute interval each time. The first interval was from 5:00am until 5:01 am ('am' portion), and the second interval was from 5:00pm until 5:01pm ('pm' portion). The selection of the intervals was made based on the fact that wet and contaminated insulators have much lower electrical strength than dry and clean insulators[13]. The first interval of the recording time was roughly fit to dew point hour at which insulators are finely moisturized. The second one was selected to see the behaviors in rather dry condition.

However, the duration of recording at each interval was definitely not optimal but this was the best during this initial phase of research. The limitation of the recording interval is incurred by the relationship between the recording resolution and the tape speed of the recorder. The higher resolution we choose, the faster must be the recording speed. If the recording speed is set fast, the tape could record very short duration of time. One VHS tape could last for 10 days with the recording scheme of high resolution in the study.

B. Data Retrieval and Conversion

For the signal Retrieval Interface in Figure 1, the National Instrument's MIO-16-E-2, a multi-purpose input/output board, was used. A data acquisition computer with National Instrument's LabWindows/CVI software was used to retrieve the analog signal from the VHS tapes and digitize it for analysis.

In each one-minute segment data, we discarded the first 10 second not to include the transient period of tape starting. We sampled data with 3840 Hz sampling rate and converted the 50 seconds data into digitized variables. Using the digitized data, for each 1-second data, we calculated crest factor[14] and sorted out frequency variables using Fourier transform in the range of 30Hz to 1920Hz (excluding 60Hz) from the phase currents of A, B, C, and neutral. However, since the neutral current is a real-time summation of the three phase currents, any single-phase change is reflected in the neutral current. Therefore in this paper, only neutral currents were analyzed.

IV. ANALYSIS OF THE RECORDED DATA

A. Parameter Analysis

During the study period, about 20 failure incidents were reported. And most failures were caused by insulator breaks. So we focused our analysis on the insulators to foretell the failures: we analyzed several parameters to isolate specific characteristic or parameter which was expected to change before and after the failure occurrence. Of course, there were chances that signatures of other failing equipment such as transformer might be included in the parameters under investigation. However, since there was no report of the other failures in our study duration, we assumed that the signatures of insulator failure be dominant.

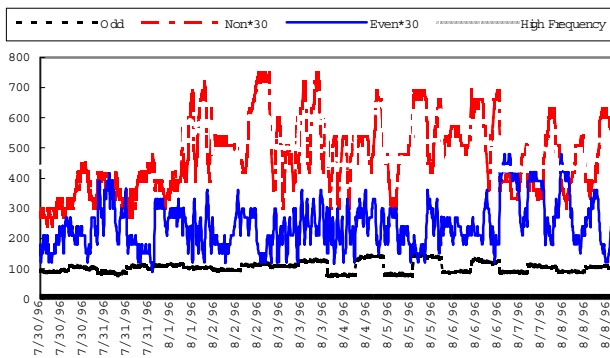

(a)

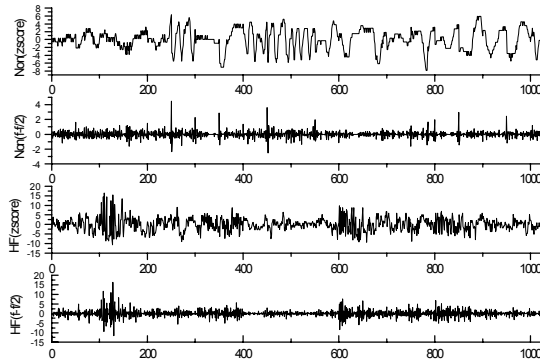

(b)

Figure 2. Behaviors of variables before and after the failure incidents: (a) Harmonic components; (b) wavelet -transform.

The parameters we investigated are: frequency components (non-, even-, and odd harmonics) and a time domain parameter (i.e., crest factor), and wavelet transform using a Daubechies wavelet [15]. The behaviors of the parameters on the data recorded in the period of July 30 to August 8, 1996 are illustrated in Figure 2. In the figure, 'am' and 'pm' portions of each day's data are concatenated and that is why, in the x-axes, same date is ticked twice. Insulator failure occurred in August 2 and 4 and these failure dates are expressed in sample numbers in Figure (b): the points 200 and 400 in x-axis are failure incidence points. Also, in Figure

2(b), the top two graphs indicate the non-harmonic component and its wavelet transformation in the ranges of $[f, f/2]$ or scale 1 of the frequency band [16], respectively. The bottom two correspond to the high-frequency component and its wavelet transform.

B. Observations

As we could see from Figure 2, a parameter (such as wavelet transformation or non-harmonic component) which is very active the day before the insulator failure comes out the day after the failure in which the faulty insulator is already replaced. Similar analysis on the data in other periods could not determine any parametric characteristic of incipient condition surrounding insulator failures. These efforts could not yield the desired parameter isolation.

V. MODIFIED ANALYSIS: EVENT-DATE ANALYSIS

A. Problem in the Parameter Isolation

A typical distribution feeder has hundreds of insulators. These insulators have been in service for varying periods of time and are in various states of health. There may be dozens or scores of insulators that are at some stage of incipient failure, and it is likely that only one or a few of the insulators will reach the point of flashover and overcurrent fault at any one point in time. Therefore, after the source of a particular fault is located and repaired, most of the partially-failed insulators are still present on the system. Therefore, much of the measurable characteristic remains even after the failure incidents.

To solve this complicated situation, we devised a strategy based on the recognition of "event" in the data. We classified a particular 1-minute segment of data as containing an "event" if there was a relatively high degree of variability in the magnitude. To determine the variability, we counted the number of zero-crossings of the component magnitude. If the count on a day's segment data was above threshold, we classified it as an "event date." Since normal noise level of the feeders are not the same, the threshold level should be determined upon examining the normal noise level of a particular feeder under investigation. We applied this new analysis on non-harmonic and high frequency components.

B. Event-Date Analysis on a Group of Data

We conducted the event-date analysis on two groups of data. We calculated the zero-crossing count on 1-minute segment of 'am' portion and 'pm' portion of the data separately. Also, we calculated the "event-date percentage" with following formula.

$$E_n[\%] = \frac{\sum_{i=1}^n S_i}{n} \times 100$$

where, $E_n[\%]$ is the "event-date percentage" of the day n , and

S_i is the date status: if the day i is an "event" date, then $S_i=1$, otherwise, $S_i=0$.

To check how the "event-date percentage" varies to the next insulator failure from the previous one, we reset the percentage to zero when it meets a failure date. After the reset, the event-date percentage calculation resumes from the first day ($i=1$) after the failure. By plotting $E_n[\%]$ on each day n , we could visualize the relationship between the "event dates" and insulator failure dates.

Non-harmonic data

On Non-harmonic non-stationary data we investigated the event dates on data recorded in July 1996. Figure 3 shows the normalized value with zero mean, zero-crossing counts for am and pm portion, the markings for event dates and failure dates, and event-date percentage.

High Frequency Data

On high-frequency data we investigated the event dates on the group of data between July 13 and August 14, 1996. Figure 4 shows the results of the analysis on high-frequency data in a similar way as depicted in Figure 3.

From Figures 3 and 4, we could see that there is a certain correlation between the event-dates and failure dates: as the event-date percentage increases the failure event appears.

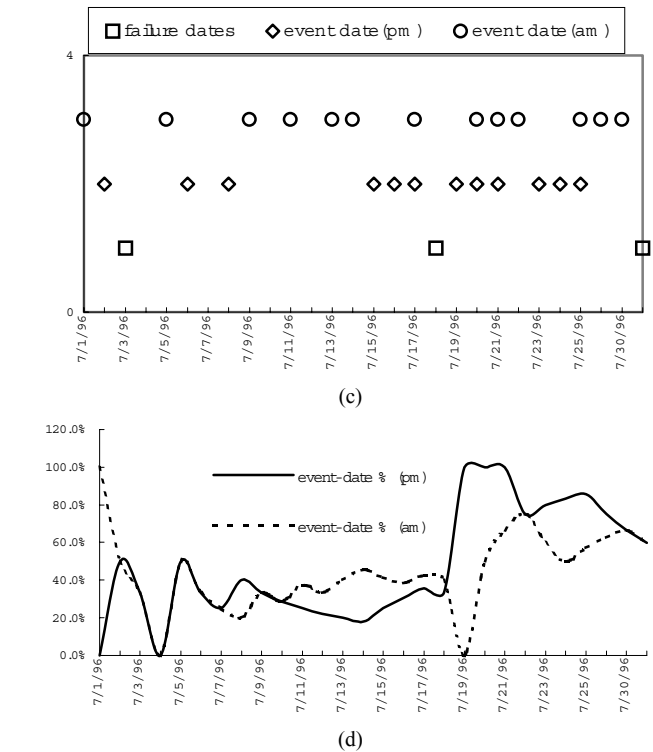
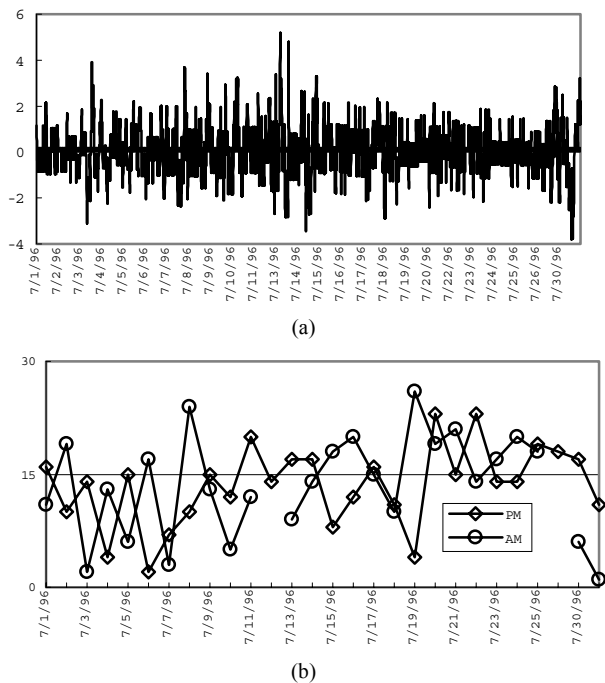

Figure 3. Plots of event-date analysis on non-harmonic data: (a) z-scored value; (b) zero-crossing counts of am and pm portion; (c) event-dates and failure dates; (d) event-date percentage.

If we attempt to formulate this relationship, we could say that "if $E_n[\%]$ reaches about 40% we may have to send out a warning for an imminent insulator failure." Even though this formula does not provide clear indication or separation for failure prediction factor for practical use, we still could get a rough sense of imminent insulator failures. For example, a hypothetical rule might state "if the percentage of dates containing events continually increases, the likelihood of failing insulators is greater." This rule presently is very broad but further data collection and analysis may lead to its refinement.

C. Event-Date Analysis on Overall Data

To check if the rough rule drawn from the above analyses can be generally applicable, we conducted the event-date analysis on all the recorded data from July 1996 till February 1997. During the recording period some parameters were not recorded: high-frequency components were not available in the months of October and November.

Non-Harmonic Data

On non-harmonic component data, we indicate the markings of event dates and fault dates, and event-date percentage in Figure 5(a) and (b), respectively.

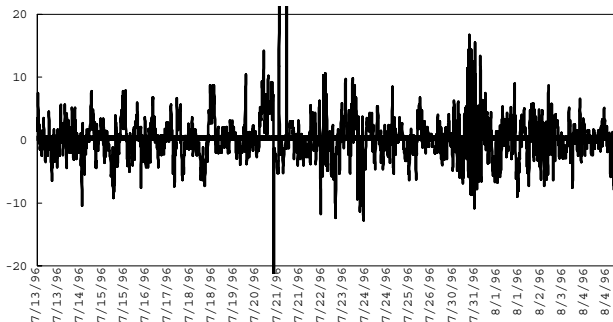

(a)

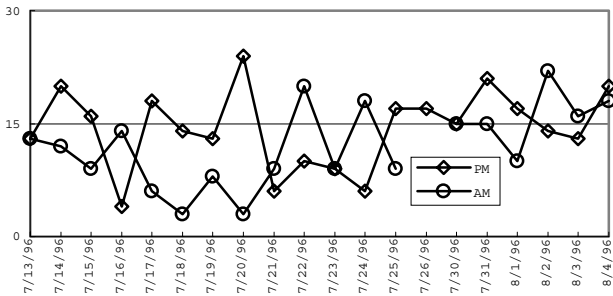

(b)

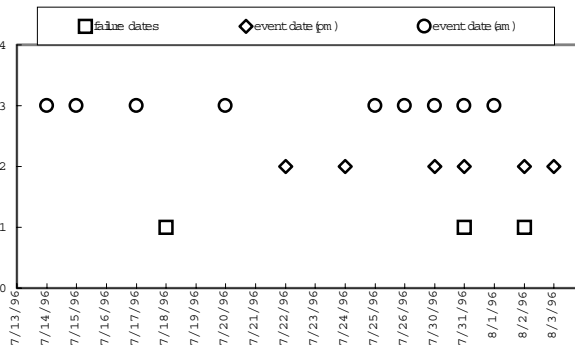

(c)

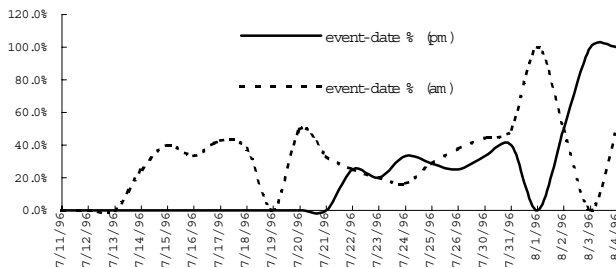

(d)

Figure 4. Plots of event-date analysis on high-frequency data: (a) z-scored non-harmonic component; (b) zero-crossing counts of am and pm portion; (c) event-dates and failure dates; (d) event-date percentage.

High-Frequency Data

On high-frequency data we similarly indicate the markings of event date and failure dates, and event-date percentage in Figure 6.

From Figures 5 and 6, a comparison of the periods containing a high percentage of "event" dates with the dates

of failures could lead to a similar rough rule statement: "If the percentage of dates containing events continually increases, the likelihood of failing insulators is greater." For the threshold of event-date percentage for failure prediction, it is roughly 30 - 40 %.

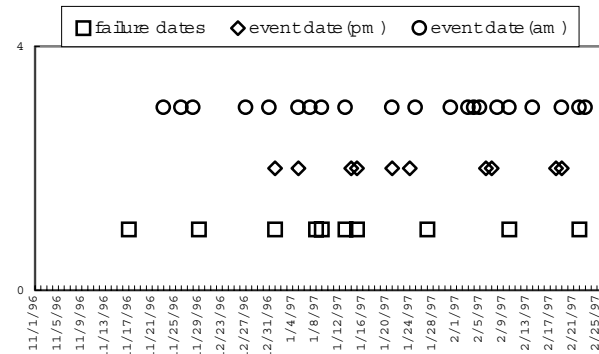
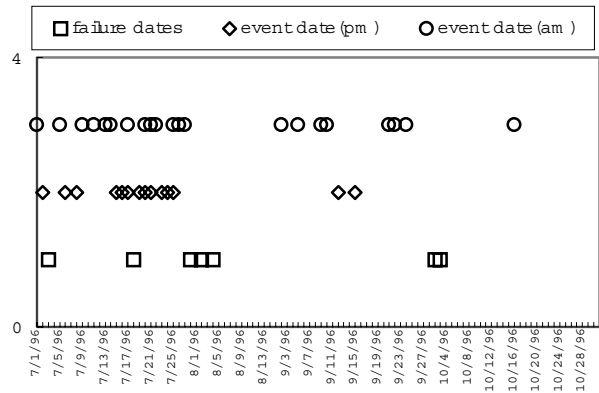

(a)

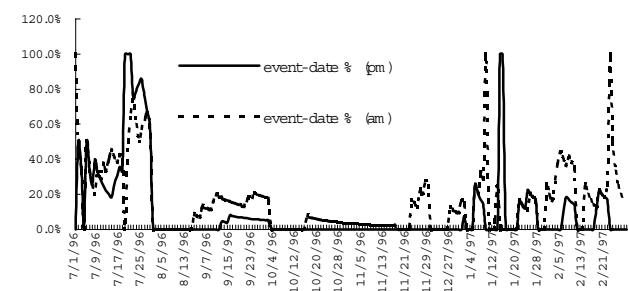

(b)

Figure 5. Plots of event-date analysis on non-harmonic data: (a) event-dates and failure dates; (b) event-date percentage.

D. Observations and Discussions

The event-date analysis does not necessarily uncover a specific single characteristic that indicates incipient fault conditions. However, we could make a rough judgment on imminent failure based on the dates containing events formulated by the "event-date percentage". We understand that the judgment rule in current form, not equipped with locating ability, is not very useful and we plan to take on this problem in the next phase of the research.

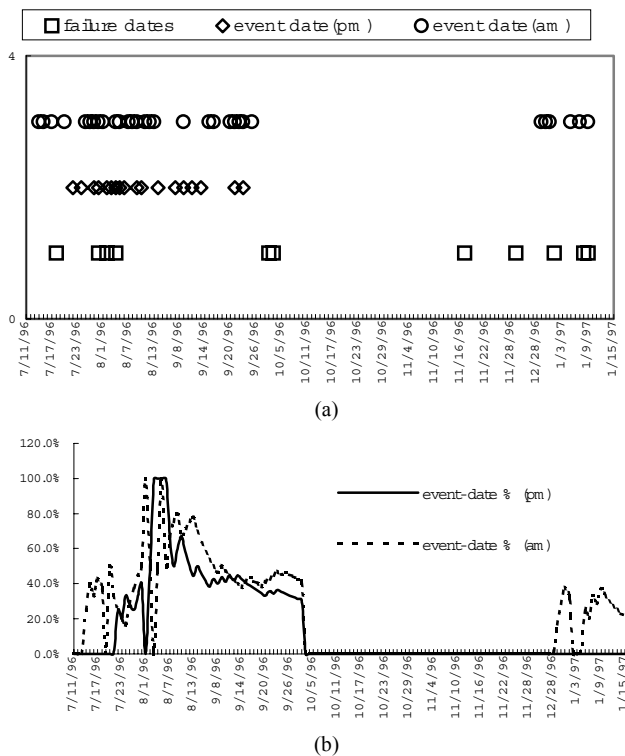

Figure 6. Plots of event-date analysis on high-frequency data: (a) event-dates and failure dates; (b) event-date percentage.

VII. CONCLUSIONS

As a feasibility study for power distribution failure prediction system to ensure highly reliable power system, we conducted real data collection and analysis. We applied data analysis methods and techniques in a hope to isolate parameters which are expected to be distinctively different before and after the insulator failures. In the isolation pursuit, however, we were not successful because there were many insulators in different health conditions generating failure signatures in the distribution line.

On the other hand, by applying "event-date" concept, we could find that non-harmonic and high-frequency component and their variability, expressed in terms of the event-date percentage, could indicate imminent insulator failures in the distribution feeder. We understand that, with the present form, the derived rule may not be of any practical use. However, we hope this rough rule can be refined in the next phase of our research by including the relationship between measured data and weather information on the feeders of different locations and conditions.

VIII. ACKNOWLEDGMENT

This research was funded by the KEPRI and we acknowledge their financial support. The data retrieval application software was built by Texas A&M researchers. The authors acknowledge their participation.

VIII. REFERENCES

- [1] K. L. Butler, "An Expert System Based Framework for an Incipient Failure Detection and Predictive Maintenance System", *Proc of 1996 Intelligent System Application to Power Systems Conference*, January 1996, pp.321-326.
- [2] C. J. Kim, M. H. Yoo, "Distribution Failure Prediction and Diagnosis Technology," *Proceedings of KIEE*, Vol. 45, No. 5, May 1995.
- [3] C. J. Kim et al, "A Study on the Distribution Incipient Failure Detection: Preliminary Results", *KIEE 97 Spring Conference*, May 1997, pp. 68-71.
- [4] "Distribution Feeder Failure Data," Distribution Department, Korea Electric Power Corp., 1994.
- [5] S. E. Habib, M. Khalifa, "A New Monitor for Pollution on Power Line Insulators," *IEE Proceedings*, Vol. 133, Pt.C., No.2, March 1986.
- [6] V. Demjaneko et al. "A Noninvasive Diagnostic Instrument for Power Circuit Breakers," *IEEE Trans. on Power Delivery*, vol. 7, no. 2, 1992.
- [7] J. Sottile, J. L. Kohler, "Techniques for Improved Predictive Maintenance Testing of Industrial Power Systems," *IEEE Trans. on Industry Application*, vol. 25, no. 6, Nov/Dec 1989.
- [8] H. Ohnishi et al., "Insulation Deterioration Monitoring System for Underground Power Distribution System," *IEEE Trans. on Power Delivery*, vol. 9, no.2, April 1994.
- [9] T. S. Sidhu, M. S. Sachdev, "On-Line Identification of Magnetizing Inrush and Internal Faults in Three-Phase Transformers," *IEEE Trans. on Power Delivery*, vol.7, no. 4, October 1992.
- [10]"Hydro-Quebec's Smart Station system keeps 16 substations in sync", *Electrical World*, December 1993, pp. 90-92.
- [11] News from EPRI Power Delivery Group, 1997.
- [12]V-Store Instrumentation Recorder, Racal Recorders Limited, Southampton, England
- [13] W. A. Chisholm et al., "The Cold-Fog Test", *IEEE PES Winter Meeting*, 96WM 099-2 PWRD.
- [14] C. J. Kim, B. D. Russell, "Analysis of Distribution Disturbances and Arcing Faults using Crest Factor." *Electric Power Systems Research*, No. 35, 1995.
- [15] A. Bruce, D. Donoho, H. Gao, "Wavelet Analysis," *IEEE Spectrum*, pp. 26-35, October 1996.
- [16] D. C. Robertson et al, "Wavelets and Electromagnetic Power System Transients," *IEEE Trans. on Power Delivery*, vol. 11, no.2, pp. 1050-1056, April 1996.

IX. BIOGRAPHIES

C. J. Kim (M '90) received his BS and MSEE degrees from Seoul National University in Korea, in 1980 and 1982, respectively. He received a Ph.D. degree from Texas A&M University in 1989. From 1990 to 1994 he worked as a post-doc. researcher and later, research faculty member for the Power System Automation Laboratory at Texas A&M University. From 1994 to 1998, he was with Dept. of Electrical Engineering at the University of Suwon. Dr. Kim's research interests include information technology and intelligent systems application to power system control, monitoring, protection, and incipient failure detection. Currently Dr Kim is with Department of Electrical Engineering at Howard University.

Jeong Hoon Shin received the B.S. and M.S.E.E. degree from KyungPook National Univ. in 1993 and 1995, respectively. He is currently a Junior Member of Technical Staff of Power System Research Lab in KEPRI. His research interests are in the areas of Predictive Maintenance on Power System, Power System Fault Diagnosis, Power System Analysis and Control.

Myeong-Ho Yoo received MSEE degree from Seoul National University in 1990. Mr. Yoo has been with KEPRI since 1980. From 1985 to 1996 He has worked as a senior research engineer in the KEPRI. Currently, Mr. Yoo is a manager of Transmission Department of a regional KEPRI office.

Gi Won Lee received his BS, MS, and Ph. D. degrees from Seoul National University, in 1984, 1986, and 1990, respectively. From 1990 to 1992, he worked as a senior researcher for Samsung Electronics R&D Center. In

1992, Dr. Lee founded Keyin System Co. and, since then, he runs the venture company as the president.