

Phase-Time Analysis of the Leakage Impulse Current of Faulty Line-Post Pin Insulators

Charles J. Kim, *Member, IEEE*, James A. Momoh, *Fellow, IEEE*, and Heung-Jae Lee, *Member, IEEE*

Abstract--Leakage impulse current of the faulty insulators was experimentally studied. The leakage impulse current was characterized in terms of the phase-time base of the applied voltage. The study showed that the leakage impulse is observed only in a distinct location in phase-time space. Based on the findings, a prioritized maintenance scheduling was proposed, which could be used for status monitoring of insulators and distribution feeders.

Index Terms--Insulator, incipient fault, breakdown mechanism, elliptic time base, phase-time relationship, partial discharge.

I. INTRODUCTION

The supply discontinuity and down time of the electric power is the main concern for power utility companies and the customers. A variety of conditions can lead to supply interruptions during fair-weather conditions. One common cause of such interruptions in the overhead feeders is broken or contaminated pole-top line-post insulators [1]. The failure mechanism of the insulators starts from the insulator contamination because contaminants build up around an insulator. Since the contaminated surface of the insulator has much higher conductivity than the normal clean surface, it provides an electrical path from the high voltage conductor to the grounded metal pin of the insulator, allowing leakage current to flow. Therefore, insulator leakage current measurements are believed to indicate the status of the insulator. Habib et. al. developed a transformer arrangement for monitoring leakage levels of an insulator chain [2]. A toroidal coil placed on the string of insulators counts the number of current bursts, whose amplitude exceeds a critical level, and transmits an alarm when a dangerous intensity is reached. Also, a recent research on the feasibility of a substation-based insulator status monitoring showed that the idea itself is positive as insulator failures could be observed at substation [3]. However, both studies demonstrated that the magnitudes of the leakage current alone could not achieve a

practical and reliable detection scheme for incipient insulator failures.

This paper reports the second part of the lengthy investigation of insulator failure that focused on the microscopic analysis of the leakage impulse currents. The first part was devoted to the macroscopic and statistical analysis [4]. The object of the microscopic analysis was to characterize the leakage current pattern of the faulty distribution insulators under dry and wet conditions in terms of the duration and the location in phase space. The analysis was performed using the sampled data that was acquired from several staged tests.

In the next two sections, the insulator failure mechanisms and the staged test set-up are briefly described. The analysis of the acquired data is next, followed by the conclusions.

II. INSULATOR FAILURE MECHANISM

It is well known that, especially in the rural distribution network, most power faults are caused by insulator failures in the distribution line, and that the majority of the insulator failures is stemmed from the natural degradation of their integrities. Hence, the behavioral characterization of insulator failure is the most important task for the "predictive maintenance" which allows the utility companies to schedule and execute the remedial action of replacing failing insulators prior to the occurrence of overcurrent faults and service interruptions.

The overall mechanism of insulator failures is still not very well understood because of the large number of non-linear parameters; however, it is relatively well known that factors such as moisture and contaminant significantly affect the failure process. Insulator failure is normally initiated as leakage current flows over a wet, contaminated surface of the insulator as illustrated in Fig. 1. When water from late-night condensation, dew, or rain accumulates on the surface of a clean insulator, the water's surface tension tends to make individual beads form on the insulator. Between these water beads will be dry sections that function as high-impedance barrier, by which the insulator maintains its integrity.

When the insulator is contaminated, the surface contamination limits the ability of the water to form beads and causes the formation of a more uniform coating over the insulator. This reduces the total dry length and the ability of the insulator that restricts the current flow [5]. When the total dry length falls below a critical level, the impressed line voltage breaks down the insulating property of the insulator surface, and leakage current flows. However, the heat generated by the surface leakage current produces the dry bands, over which local arcs may be initiated. Depending on

This work was supported in part by the Korea Science and Engineering Foundation under Grant #1999-2-30200-007-3.

Charles J. Kim is with the Department of Electrical Engineering, Howard University, Washington, DC 20059 USA (e-mail: ckim@howard.edu).

James A. Momoh is with the Department of Electrical Engineering, Howard University, Washington, DC 20059 (e-mail: jm@scs.howard.edu).

Heung-Jae Lee is with the Department of Electrical Engineering, Kwang Woon University, Seoul, Korea (e-mail: hjlee@daisy.kwangwoon.ac.kr).

the rate of the breakdown and the water evaporation, the arcs may grow over the surface and self-extinguish, continue sporadically, or increase to a level of destructive high-current flashover. The flashover leads to overcurrent fault and service interruption.

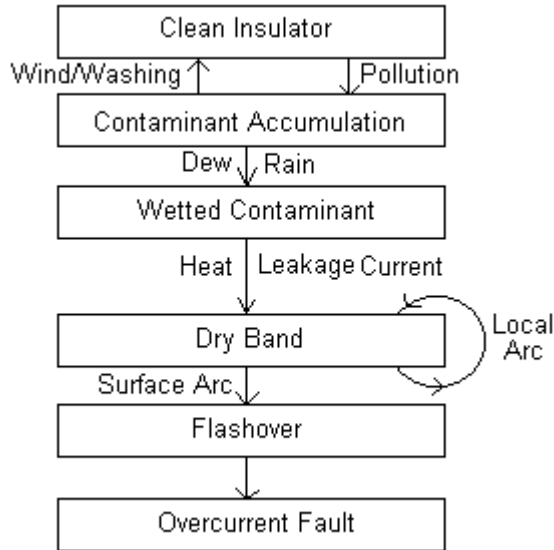

Fig. 1. Insulator failure mechanism.

III. STAGED TESTS AND DATA ACQUISITION

To analyze the behavior of the insulator leakage currents, insulator tests were staged on selected faulty pin-post distribution insulators. The experiment set-up and the staged experiments are discussed here.

A. Faulty Insulators

To perform experiments on faulty insulators, insulators that were once failed and removed from service were collected. Among them were the four line-post pin insulators once installed in a rural distribution feeder of Korea Electric Power Corporation (KEPCO). We tested the "unhealthiness" of each insulator in insulation level by measuring insulation current, percent power factor, and capacitance between the top of an insulator and the grounded metal pin of the insulator. The impressed voltage level to the clamp attached on the top of the insulator was selected as the nominal phase voltage level of KEPCO feeders, 13kV, at the frequency of 60 Hz. The insulation level measurement was done using a M4000 Automated Insulation Analyzer [6]. The analyzer automatically measured and displayed insulation current (I), power loss (P), percent power factor (pf), and capacitance (C) of the object insulator. In addition to the four faulty insulators, the insulation level for a normal and healthy insulator was measured, in order to compare with those of the faulty insulators. The insulation test results are shown in Table 1. From the table, it is seen that insulator #3, with the highest magnitude of current and power loss, is the "unhealthiest" one, and this faulty insulator is the primary object of the microscopic analysis.

B. Staged Tests

The main purpose of the staged tests on the faulty insulators was to investigate the leakage current behavior, and eventually find some decisive parameters for early detection of failing insulators. One of the new parameters selected for the behavioral investigation was the inception point of leakage impulse current. The data collection for insulator leakage current study was done in July 1997 at the KEPCO's Equipment Inspection and Testing Station, which inspects and performs random sample tests on the distribution equipment delivered from the contractors. Fig. 2 illustrates the experiment set-up for the staged tests. In the tests, the faulty insulators were tested under two conditions: dry and wet surfaces. To wet the insulator, a water sprayer system of the Station was utilized.

TABLE I INSULATION TEST RESULTS OF THE INSULATORS

| Insulators | I [mA] | P [W] | pf [%] | C [pF] | |
|-------------------|--------|-------|--------|--------|------|
| Normal Insulator | 0.034 | 0.009 | 2.79 | - | |
| Faulty Insulators | #1 | 0.238 | 0.187 | 7.86 | 63.0 |
| | #2 | 0.239 | 0.161 | 6.73 | 63.1 |
| | #3 | 0.304 | 1.197 | 39.36 | 74.1 |
| | #4 | 0.252 | 0.220 | 8.72 | 66.5 |

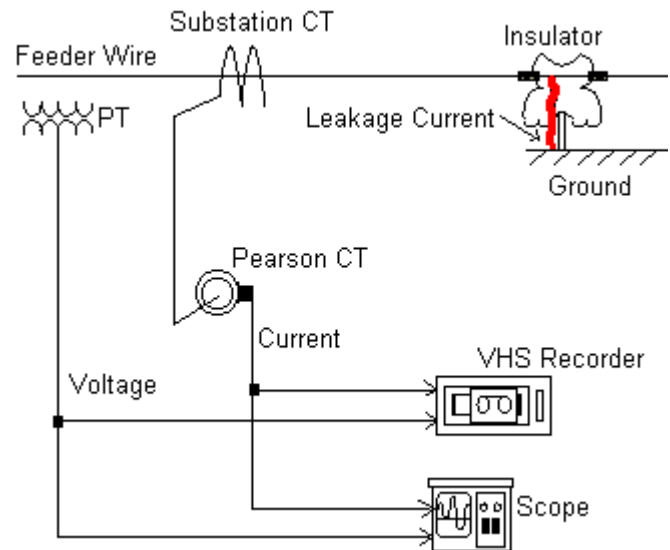

Fig. 2. Leakage impulse data acquisition set-up.

As in the real situation, a distribution feeder wire was clamped on top of an insulator, and a ground wire was connected to the metal pin of the insulator. The voltage level of 13 kV, stepped-up from 220V with a transformer, was impressed for several minutes for each of the tests. To measure the voltage, we stepped down the high voltage via a distribution PT to the nominal 220V. This voltage was further lowered to 20V before connected to the input terminals of the scope and the VHS recorder. A distribution CT was connected to the distribution wire to induce leakage current, and a precision Pearson Current Monitor CT [7] was used to further

lower the induced leakage current. The reduced level of the leakage current was fed to the recorder.

A Racal V-Store 16 instrumentation recorder [8], configured with FM signal electronics, was used to record the leakage currents and the impressed voltage on VHS videocassette tape. The sampling frequency of the signal was 10 kHz. National Instrument's Virtual Instrument software with an enhanced I/O interface card, AT-MIO-16-E-1, was used to retrieve the stored analog signal from the video tapes and to convert the analog data to a digital format. The digitized data in binary format was later sent to Howard University for analysis.

IV. ANALYSIS OF THE LEAKAGE IMPULSE DATA

The analysis of the digitized data of the staged insulator tests was carried out at the Center for Energy Systems and Control (CESaC) at Howard University. The binary data was retrieved and converted to text format using National Instrument's LabView® software and an enhanced I/O interface card [9]. The text-formatted data was imported to Microsoft Excel® environment. The analysis using the spreadsheet software was focused on the inception point and location of the leakage impulse current against the impressed phase voltage. Since the period of sampling was 0.1 ms, only the impulses longer than 0.1 ms duration were recorded; this investigation is limited to the impulses longer than that duration.

This paper only reports the results of the analysis of the "unhealthiest" insulator, the faulty insulator #3, which showed a consistent leakage impulse behavior in inception point and location in several tests under dry and wet conditions. The magnitude of the impulse currents, however, varied wildly in a test, and from a test to another, an impulse magnitude reached up to 1000 mA in a test, while others barely touched the level of 30 mA. To analyze the impulse current in a wide range, we separated the impulses in two groups: strong impulse current and weak impulse current, by a threshold level of 100mA. The 100mA threshold level was selected because the magnitude lower than the value could be hardly recognizable without decreasing the scale factor. This section reports the strong and weak impulse current behaviors under dry and wet conditions.

A. Leakage Impulse Behavior in Dry Condition

1) Strong impulse current: A portion of the leakage current and the sinusoidal voltage waveform, depicted in Fig. 3, shows four strong impulse. It could be seen that the inception points of the impulses are both either at positive or negative peak, and between a zero crossing and a negative peak of the voltage. The magnitudes of the impulses are in the range of 100mA to 900 mA. However, the durations of the impulses are not clearly shown. Changing the scale factor of the axis of the sample number would show the impulse duration; however, it would not show all the impulses, since the reduced scale will show only the much smaller portion of the waveform. In the time-domain waveform, a trade-off between the numbers of data point and the level of resolution will have to be chosen, since they are negatively related.

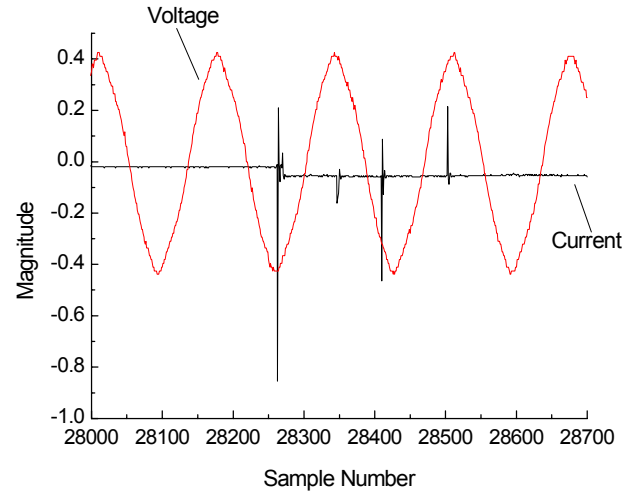

Fig. 3. The sinusoidal voltage and leakage current waveform.

To display the inception point and the duration of the impulse current against the sinusoidal voltage in a satisfactory resolution, the "phase-time" diagram was adopted, which superimposes the leakage impulse current to the impressed voltage and draws them on an elliptical time base [10]. The ellipse is positioned in such a way that the top and bottom coincide with the plus and minus crests of the voltage sine wave, and the ends, with the zero crossings.

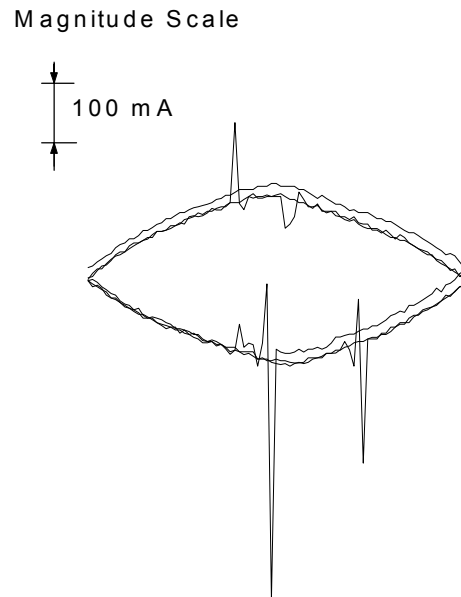

Fig. 4. Leakage impulse current on elliptic time base.

For 60 Hz voltage phase, it is about 8.33 ms from one end to the other end of the ellipse and about 4.17 ms from one end to the top or the bottom. The durations in time are equivalent to the durations in phase angle of 180° and 90° , respectively.

Fig. 4 is the phase-time representation of the time-domain waveform of the voltage and leakage current shown in Fig. 3.

The phase-time diagram indicates the exact inception points and the durations of the leakage impulses with higher precision: two leakage impulses are 1 - 2 ms before the peaks and the durations of all impulses are between 0.25 - 0.5 ms. The phase-time diagram has a distinctive advantage over the regular time-domain waveform in depicting a large amount of leakage impulse data without losing the necessary resolution for the discernment of the inception point and duration.

2) Weak impulse currents: A time-domain waveform of the weak leakage impulses of about 500 samples, and the phase-time diagram are shown in Fig. 5.

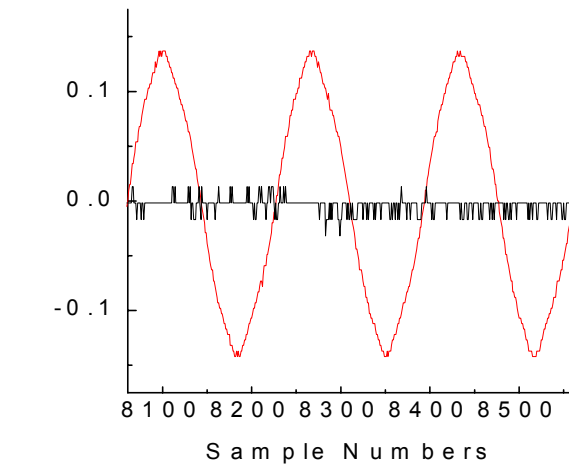

Magnitude Scale

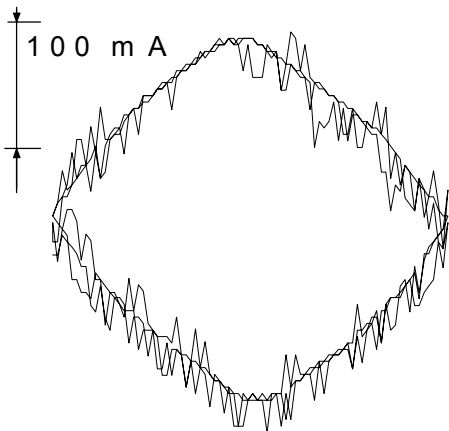

Fig. 5. Time-domain waveform and phase-time diagram of weak leakage impulses in dry condition.

The magnitudes are much smaller than those of the strong impulses; therefore, even the phase-time diagram cannot clearly discriminate the leakage currents and the normal

background noise. However, impulses of about 2 ms length could be seen both near the positive peak, and between positive peak and zero crossing.

C. Leakage Impulse Behavior in Wet Condition

1) Strong impulse current: Fig. 6 illustrates the time-domain waveform and the phase-time diagram of a portion of the strong leakage impulse currents sampled from the faulty insulator under wet condition.

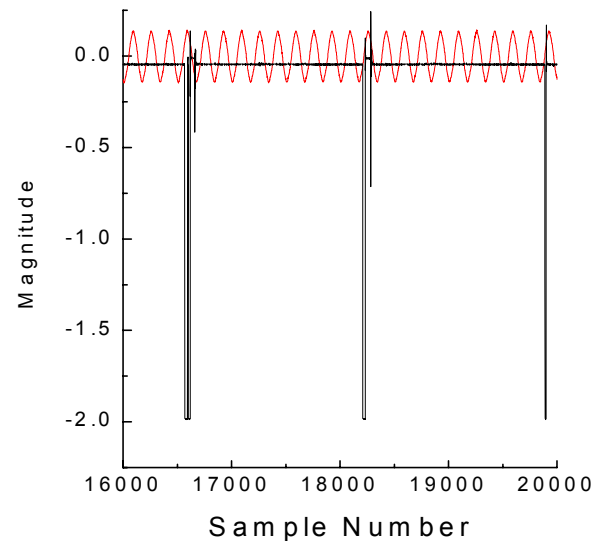

Magnitude Scale

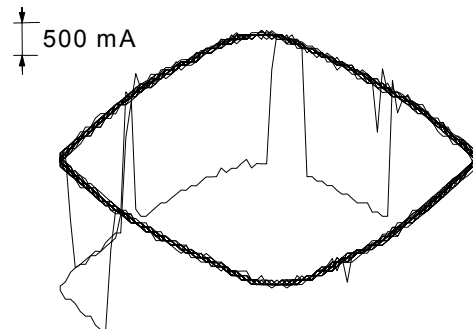

Fig. 6. Time-domain waveform and phase-time diagram of strong leakage impulses in wet condition.

The phase-time diagram shows four long and three short pulses: the long ones last for 2 - 3 ms and the short ones, for 0.5 ms. The pulses' inception points are various: at a zero crossing, just after a peak, a quarter cycle before a zero crossing, and a quarter cycle before a peak. All the long pulses are dominantly negative, and their durations are longer than under dry conditions. Under wet conditions, leakage currents are easily initiated by moisture; therefore, it is expected that leakage currents last long and continue

sporadically in short pulses, limited by the rapid heating and consequent evaporation of the moisture.

2) Weak impulse current: Fig. 7 depicts the time-domain waveform and phase-time diagram of a portion of the weak leakage impulse currents under wet conditions. The phase-time diagram indicates two long pulses at the same phase location: the 2 ms long pulses are initiated a quarter cycle after the positive peak.

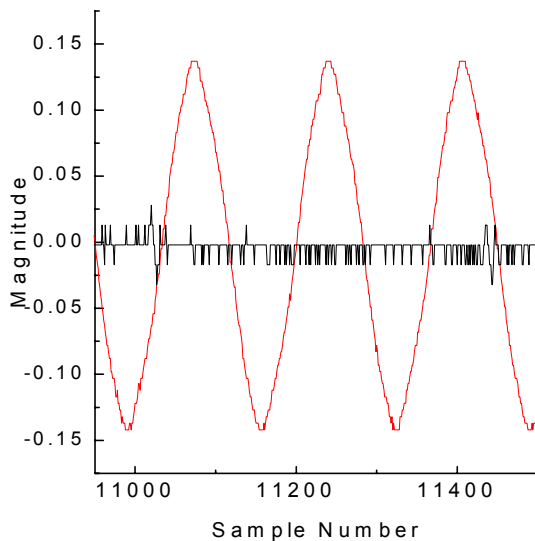

Fig. 7. Time-domain waveform and phase-time relationship diagram of weak impulses in wet condition.

D. Observations

Even though the data sets are not big enough to draw a general conclusion from the phase-time information of the leakage impulse of the faulty insulator, one very distinctive feature was found: contrary to the well-accepted assumption

that arcs develop near the peak voltage, the insulator leakage impulses are initiated before and after the peak. Since the eventual goal of the leakage analysis is to come up with a scheme for the detection of the leakage currents, we collectively presented the findings from the phase-time analysis in the detection point of view in Fig. 8.

The phase plane diagram indicated the polar-coordinated phase angle in degree and duration in millisecond. The round bands around the origin indicate where, in terms of the phase angle against the voltage, the leakage impulses are generally observable and how long they usually last. For example, for the strong impulse under wet conditions, the round band made by the angles between 325° and 135° and durations between 2 and 3 ms indicates that a strong impulse can be observable at any phase location inside the band, and it likely lasts 2 - 3 ms.

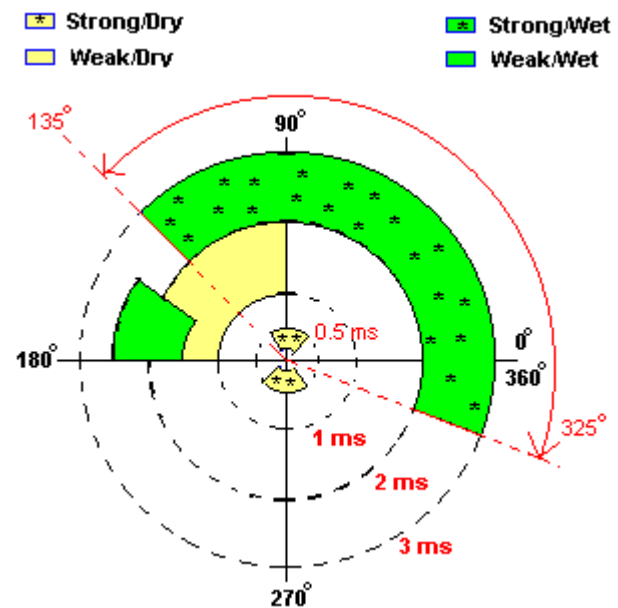

Fig. 8. Phase plane illustration of the leakage impulse currents of the faulty insulator.

Since the weak leakage impulses are not sufficiently observable, only the strong impulses in dry and wet conditions are considered for drawing a simple detection rule for faulty insulators. Except for the small band in the negative half cycle, which indicates the general location of a strong impulse of very short duration, the strong impulses are observable at $325^\circ - 135^\circ$, and they last for 0.25 - 3 ms. Actually, there are no sufficiently big impulses between $180^\circ - 325^\circ$. The limited phase location is a very distinctive feature of the leakage impulses of faulty insulators compared with those of other partial discharge patterns. According to an extensive study of the various partial discharge patterns, the impulses are present all around the phase angle space [10].

The rule drawn from the experiment provides a refined detection scheme of faulty insulators: not all the leakage impulses but only those in a certain phase-time location, like $325^\circ - 135^\circ$, should be measured and counted. This simple rule, incorporated with utility's feeder monitoring or

maintenance system, can be used as a tool for both identifying insulator "unhealthiness" status and discriminating the failing from other equipments undergoing discharge processes of degradation. The discriminatory role of the rule is very important in that it minimizes the potential of falsely alarming of imminent insulator failures. Fig. 9 illustrates a block diagram of the insulator status monitoring that connects the leakage current acquisition and insulator status identification to the *distribution maintenance program* of a utility company. The acquired voltage and current samples are converted to a phase-time data that passes through a phase filter of $315^\circ - 135^\circ$ band. Counting the number of phase-band filtered impulses will give a status of the insulators in a feeder. The status information allows the maintenance program to prioritize the feeder maintenance scheduling. In addition, the insulator status monitoring can be utilized to a start-up *predictive maintenance program*, by which utility could save manpower, reduce power outage and downtime, and avoid the revenue loss.

The present results may not be applicable to all distribution feeders in all situations, and more study and investigation of the insulator failure behavior in real distribution feeders is needed. The validation of the findings will continue using other distribution systems, and any suggestions for collaborative efforts from domestic and foreign utility companies are welcome.

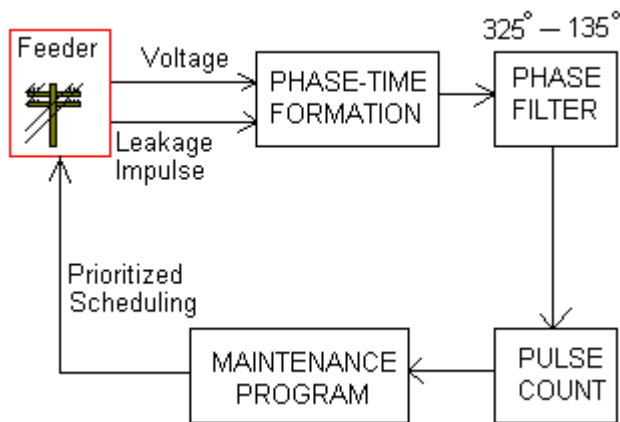

Fig. 9. An illustration of the insulator status monitoring.

V. CONCLUSIONS

The leakage current data obtained from the staged tests on faulty insulators under dry and wet conditions was analyzed to microscopically characterize the behavior of the leakage impulses with respect to the voltage phase. The phase-time analysis showed the leakage impulses started and existed only in a distinctive phase band. This finding can be applied to identify the "unhealthiness" of the insulators in question. The insulator status monitoring scheme, which counts only the impulses passed through a phase-band filter, has a great potential, merged with the existing distribution maintenance program, to provide a prioritized maintenance scheduling for reliable electricity supply. More analysis on insulators with

different levels of "unhealthiness" in other utility systems is needed to validate the findings reported here.

VI. ACKNOWLEDGMENT

The authors gratefully acknowledge the contribution of Mr. Jeong-Hoon Shin of Korea Electric Power Research Institute (KEPRI) for the work on the leakage data acquisition, and the institutional support of KEPRI and KEPCO. The authors extend their acknowledgment to the Center for Energy Systems and Control (CESaC) at Howard University for the equipment for the data analysis.

VII. REFERENCES

- [1] C. J. Kim, M. H. Yoo, "Distribution Failure Prediction and Diagnosis Technology," *Proceedings of KIEE*, Vol. 45, No. 5, May 1995.
- [2] S. E. D. Habib, M. Khalifa, "A New Monitor for Pollution on Power Line Insulators, Part 1: Design, Construction and Preliminary Tests," *IEE Proceedings*, Vol. 133, Pt. C, No. 2, March 1988.
- [3] S. Kan, *Failure Characterization of Distribution Insulator and New Methods of Predictive Maintenance*, Ph.D. Dissertation, Texas A&M University, 1998.
- [4] C. J. Kim et al, "A Study on the Characterization of the Incipient Failure Behavior of Insulators in Power Distribution Line," *IEEE Transactions on Power Delivery*, Vol. 14, No. 2, pp. 519-524, April 1999.
- [5] S. Khan, K. L. Butler, B. D. Russell, "A Predictive Maintenance Approach for Power Distribution Systems," *Proc. of 27th North American Power Symposium*, Bozeman, Montana, pp. 700-707, October 1995.
- [6] M4000 Intelligent Insulator Analyzer, Doble Engineering Co., MA.
- [7] Pearson Current Monitor, Pearson Electronics, Inc., Palo Alto, CA.
- [8] V-Store Instrumentation Recorder, Racal Recorders Limited, Southampton, UK.
- [9] NI-DAQ and LabWindows/CVI, National Instrument, Austin, Texas.
- [10] F. H. Kreuger, *Partial Discharge Detection in High-Voltage Equipment*, 1989, Butterworths, London, UK.

VIII. BIOGRAPHIES



Charles J. Kim (M '90) received a Ph.D. degree in Electrical Engineering from Texas A&M University in 1989. From 1990 to 1994 he was a post-doctoral research associate, and later, a research faculty member at Texas A&M University. From 1994 to 1998, he was an assistant professor at the University of Suwon. Since 1999, he is with the Department of Electrical Engineering at Howard University. Dr. Kim's research interests include power line

communication, embedded computing, intelligent systems application, and incipient failure detection.



James A. Momoh (M '76, SM '89, F '99) received the B.S.E.E. degree from Howard University in 1975, the M.S.E.E. degree from Carnegie Mellon in 1976, the M.S. in Systems Engineering from the University of Pennsylvania in 1980 and the PhD in Electrical Engineering from Howard University in 1983. Dr. Momoh is a former chairman of the Electrical Engineering department at Howard University and is also the director of the Center for

Energy Systems and Control (CESaC). He is currently serving as Program Director at the National Science Foundation (NSF) in the Engineering Directorate, Division of Electrical Communication and Systems (ECS). His research interests include Power System Reliability and Power System Optimization, Automation and Intelligent Systems, Economics and Risk Assessment in a Deregulated Power System Environment. He is currently developing an interdisciplinary research/education program in Power, Economics, Regulation and Environmental Adaptive Systems. He has received several awards/honors including the 1987 Presidential Young

Investigator Award, 1989 ASEE Excellence Educator recipient and an IEEE Fellow.



Heung-Jae Lee (M '84) received BS, MS, and Ph.D. degrees from Seoul National University, in 1983, 1986 and 1990, respectively, all in electrical engineering. His major research interests are expert systems, neural networks, and fuzzy systems applications in power system operation areas including computer applications. During 1995-1996, he was a visiting professor at the University of Washington. He is currently a professor at Kwang Woon University.