

## Class Note 22: Capacitors, Inductors, and Op Amp Circuits

**A. Capacitors**

1. A capacitor is a passive element designed to store energy in its electric field.
2. A capacitor consists of two conducting plates separated by an insulator (or dielectric). In many applications, the plates may be aluminum foil while the dielectric may be air, ceramic, paper, or mica.
3. Commercially available capacitors are, by the dielectric materials they are used of, polyester capacitors (light and stable), film capacitors, and electrolytic capacitors (high capacitance).

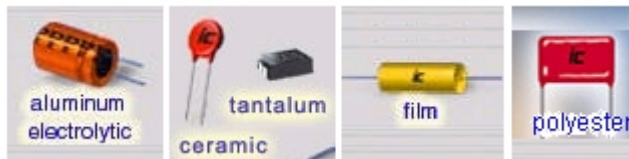

4. When a voltage source ( $v$ ) is connected to a capacitor, the amount of charge stored ( $q$ ) is directly proportional to the applied voltage:  $q = Cv$ , where  $C$ , the constant, is the *capacitance* of the capacitor. In other words, capacitance is the ratio of the charge on one plate of a capacitor to the voltage difference between the two plates.
5. The unit of the capacitance is the farad (F), in honor of the English physicist Michael Faraday (1791-1867).  $1 \text{ F} = 1 \text{ Coulomb/Volt}$ .

6. The equation  $q = Cv$  can now be changed, since  $i = \frac{dq}{dt}$ , to  $i = \frac{dq}{dt} = \frac{d(Cv)}{dt} = C \frac{dv}{dt}$ .

7. Voltage-current relationship can be obtained by integrating both sides of  $i = C \frac{dv}{dt}$ :

$$v(t) = \frac{1}{C} \int_{t_0}^t i(x) dx + v(t_0)$$

8. The energy stored in a capacitor, since the instantaneous power delivered to the capacitor is

$$p = vi = vC \frac{dv}{dt}, \text{ can be: } w = \int_{-\infty}^t p d\tau = C \int_{-\infty}^t v \frac{dv}{dt} d\tau = C \int_{-\infty}^t v dv = \frac{1}{2} Cv^2(t) - \frac{1}{2} Cv^2(-\infty) = \frac{1}{2} Cv^2$$

9. Important properties of a capacitor

(a) Note that, from  $i = C \frac{dv}{dt}$ , when the voltage across a capacitor is not changing with time, the current through the capacitor is zero. ----> A capacitor is an open circuit to DC.

(b) Note that, from  $v(t) = \frac{1}{C} \int_{t_0}^t i(x) dx + v(t_0)$ , the voltage on the capacitor cannot change abruptly; instead, the voltage must be continuous.

(c) However, the current through a capacitor can change instantaneously.

(d) An ideal capacitor does not dissipate energy. It takes power from the circuit when storing (or charging) energy and returns previously stored energy when delivering (or discharging) power to the circuit.

10. The equivalent capacitance of series-connected capacitors is the reciprocal of the sum of the reciprocals of the individual capacitances:  $\frac{1}{C_{eq}} = \sum_{k=1}^n \frac{1}{C_k}$

11. The equivalent capacitance of parallel-connected capacitors is the sum of the individual capacitors:  $C_{eq} = \sum_{k=1}^n C_k$

12. Example Problems: The two series-connected capacitors are connected to the terminals of a black box at  $t=0$ . The resulting current  $i(t)$  for  $t>0$  is known to be  $i(t) = 900e^{-2500t}$  [uA]

- (a) How much energy was initially stored in the series capacitors?
- (b) Find  $v_1(t)$  for  $t>0$
- (c) Find  $v_2(t)$  for  $t>0$
- (d) find  $v(t)$  for  $t>0$
- (e) How much energy is delivered to the black box in the time interval  $0<t<\infty$ ?

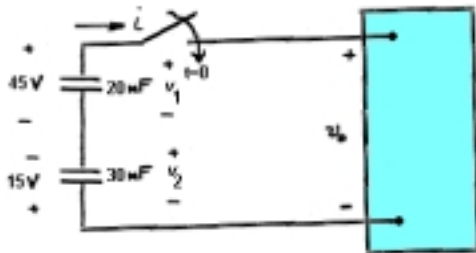

## B. Inductor

1. An inductor is a passive element designed to store energy in its magnetic field.
2. A practical inductor is usually formed into a cylindrical coil with many turns of conducting wires.



3. The voltage across an inductor is directly proportional to the time rate of change of the current through the inductor:  $v(t) = L \frac{di(t)}{dt}$ , where L is the constant of proportionality called the *inductance* of the inductor, which is the property whereby an inductor exhibits **opposition to the changes of current flowing** through it.

4. The unit of inductance is the henry (H), named in honor of the American inventor Joseph Henry (1797-1878). 1 henry equals 1 volt-second per ampere.

5. The current-voltage relationship is:  $i(t) = \frac{1}{L} \int_{t_0}^t v(y) dy + i(t_0)$

6. The energy stored in an inductor, since the power delivered to an inductor is  $p = vi = L \frac{di}{dt} \cdot i$ ,

can be:  $w = \int_{-\infty}^t p d\tau = \int_{-\infty}^t (L \frac{di}{dt}) i d\tau = L \int_{-\infty}^t i di = \frac{1}{2} Li^2(t) - \frac{1}{2} Li^2(-\infty) = \frac{1}{2} Li^2$

7. Important properties of an inductor.

(a) Note that, from  $v(t) = L \frac{di(t)}{dt}$ , the voltage across an inductor is zero when the current is constant. ----> An inductor acts like a short circuit to DC.

(b) Note that, from  $i(t) = \frac{1}{L} \int_{t_0}^t v(y) dy + i(t_0)$ , the current through an inductor cannot change instantaneously.

(c) Note that, however, from  $v(t) = L \frac{di(t)}{dt}$ , the voltage across an inductor can change abruptly.

(d) An ideal inductor does not dissipate: the energy stored in it can be retrieved at a later time. The inductor takes power from the circuit when storing energy and delivers power to the circuit when returning previously stored energy.

8. The equivalent inductance of series-connected inductors is the sum of the individual

inductances:  $L_{eq} = \sum_{k=1}^n L_k$

9. The equivalent inductance of parallel inductors is the reciprocal of the sum of the reciprocals

of the individual inductances: 
$$\frac{1}{L_{eq}} = \sum_{k=1}^n \frac{1}{L_k}$$

10. Practical Problem

a. Background

- (i) ICs are rectangular pieces of silicon.
- (ii) Electrical contact between the silicon and metals pins are made with fine gold wire, called wire bond (Fig. A).
- (iii) The chip is then coated in plastic to protect from physical damage. (Fig. B)
- (iv) Since wires are not perfect conductors, they have resistance and inductance.
- (v) In most cases, wire resistance and inductance are negligibly small.
- (vi) However, the current (being used by the chip (or processor)) changes quickly, wire inductance can play a significant role.

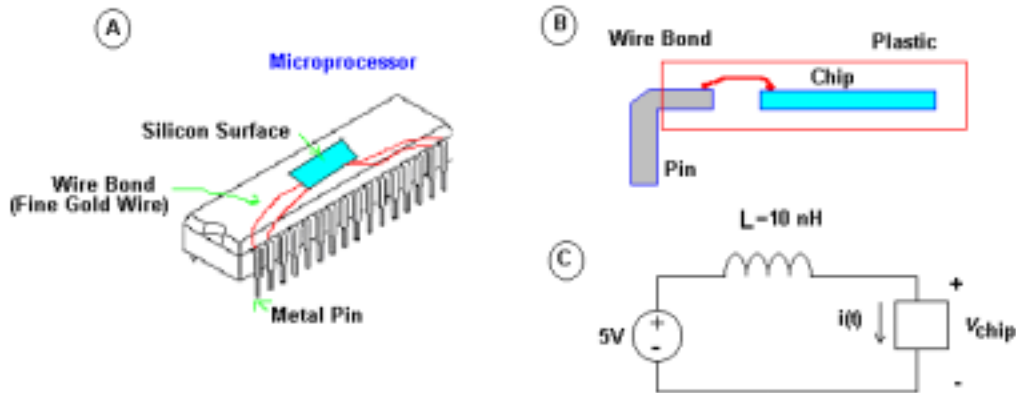

b. Analysis

- (i) We now examine the influence of the small wire inductance to the voltage across a high speed microprocessor. (See Fig. C for an equivalent circuit with the wire bond modeled by the 10 nH inductor)
- (ii) The chip supply voltage is represented by 5V voltage source.
- (iii) The current  $i(t)$  represents the current being used by the microprocessor. And this current demand changes, as the microprocessor executes various functions. An example of current change is shown in Fig. D.

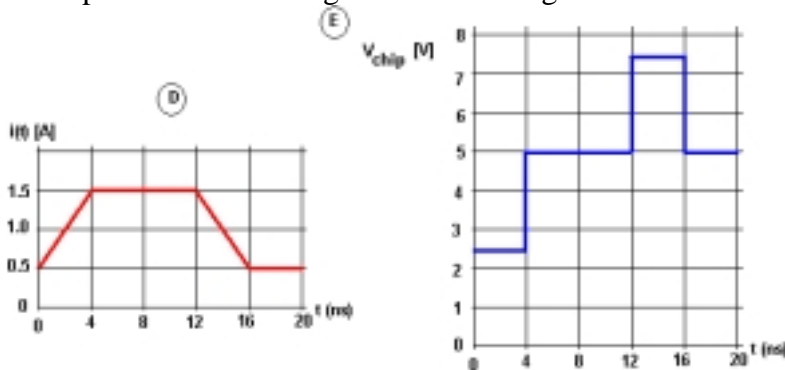

(iv) Then, voltage across the chip can be expressed by:

$$V_{chip}(t) = 5 - v_L = 5 - L \frac{di(t)}{dt} = 5 - 10 \cdot 10^{-9} \cdot \frac{di(t)}{dt}$$

(v)  $\frac{di(t)}{dt}$  calculation and chip voltage table for 4 time periods:

	0 - 4 ns	4 - 12 ns	12 - 16 ns	16 - 20 ns
$\frac{di(t)}{dt} = \frac{\Delta i}{\Delta t}$	$\frac{1.5 - 0.5}{4} = 2.5 \times 10^8$	0	$\frac{0.5 - 1.5}{4} = -2.5 \times 10^8$	0
$L \cdot \frac{di(t)}{dt}$	2.5	0	-2.5	0
$V_{chip}(t)$	2.5	5.0	7.5	0

(vi) The resulting chip voltage is illustrated in Fig.E. As we see, the voltage swings much and the chip voltage is not stable at all.

(vii) Then, how can we have a more stable chip voltage?

(viii) The answer comes from the chip voltage equation. If we reduce the inductance  $L$ , then the sudden voltage shot or drop would be reduced.

(ix) Let's add one more wire bond between the chip and the metal pin. (See Fig. F)

(x) See Fig. G. for a new equivalent circuit.

(xi) Then, the current will be equally divided in to two inductors.

(xii)  $\frac{di(t)}{dt}$  calculation and chip voltage table for 4 time periods:

	0 - 4 ns	4 - 12 ns	12 - 16 ns	16 - 20 ns
$\frac{di(t)}{dt} = \frac{\Delta i}{\Delta t}$	$\frac{0.75 - 0.25}{4} = 1.25 \times 10^8$	0	$\frac{0.25 - 0.75}{4} = -1.25 \times 10^8$	0
$L \cdot \frac{di(t)}{dt}$	1.25	0	-1.25	0
$V_{chip}(t)$	3.75	5.0	6.25	0

(xiii) The resulting chip voltage is illustrated in Fig.H. As we see, the voltage swings less and the chip voltage is more stable. By adding more wire bonds, we could further stabilize the chip voltage.

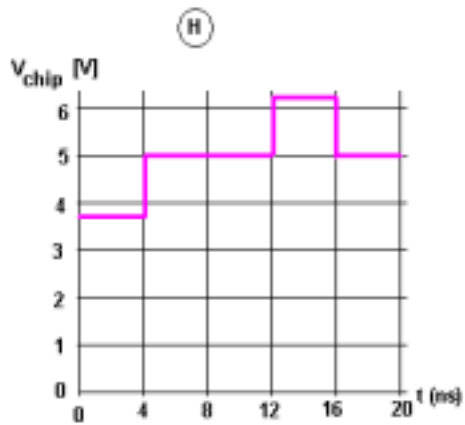
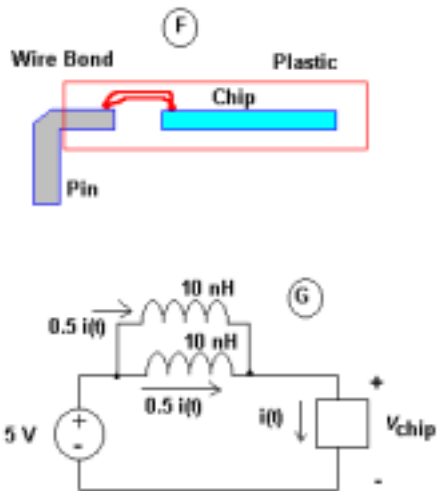

11. Example Problem: The voltage at the terminals of the 300  $\mu\text{H}$  inductor of the circuit (a) is shown in (b). The inductor current  $i$  is known to be zero before time  $t=0$ . Derive the expression for  $i$  (for  $t>0$ ) and sketch it.

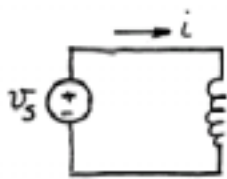

a

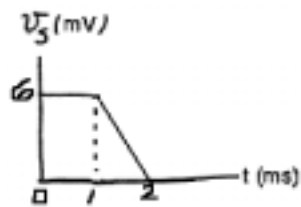

b

SOLUTION:

12. Another Example Problem: Initially there was no energy stored in the 25 H inductor when it was placed across the terminals of the voltmeter (with full-scale of 50 V). At  $t=0$ , the inductor was switched instantaneously to position **b** where it remained for 1 second before returning instantaneously to position **a**. What will be the reading of the voltmeter be at the instant the switch returns to position **a**? The d'Arsonval movement has the rating of 50mV@ 1mA. Note that  $V_s=20$  [mV].

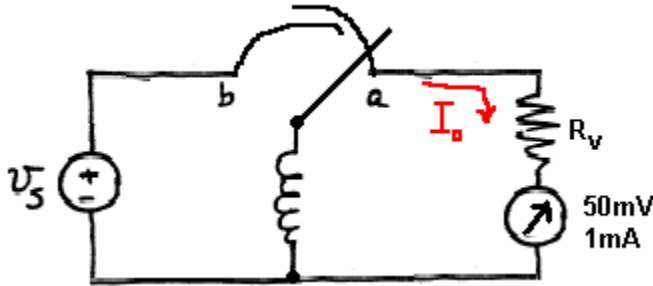

SOLUTION:

13. Example Problem: Find  $i(t)$  with voltage  $v(t)=0$  for  $t<0$ , and  $v(t)=20te^{-10t}$  for  $t>0$ . Assume that  $i(0)=0$

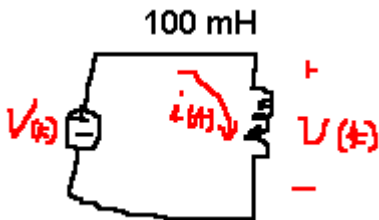

SOLUTION:

### C. The Rest of the Operational Amplifier

1. In the previous chapter, we discussed about the following op amp circuits: summer and subtractor.
2. We will discuss two more op amp circuits that had been widely used in analog computers: integrator and differentiator.
3. An **integrator** is an op amp circuit whose output is proportional to the integral of the input signal.
  - (a) Consider a circuit below. This is the familiar inverting amplifier circuit, replacing the feedback resistor by a capacitor.

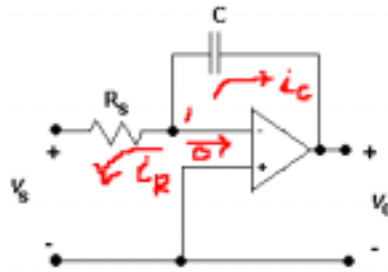

(b) A node-voltage equation at node 1:  $i_R + i_C = 0$ , where  $i_R = \frac{0 - v_s}{R_s}$  and  $i_C = -C \frac{dv_o}{dt}$ .

(c) Therefore, the current equation becomes:  $\frac{v_s}{R_s} = -C \frac{dv_o}{dt} \rightarrow dv_o = -\frac{1}{RC} v_s dt$

(d) Integrating both sides gives  $v_o(t) - v_o(0) = -\frac{1}{RC} \int_0^t v_s(t) dt$

(e) Assuming  $v_o(0)=0$  (discharging the capacitor prior to the application of the input signal), we have  $v_o(t) = -\frac{1}{RC} \int_0^t v_s(t) dt$ .

4. A **differentiator** is an op amp circuit whose output is proportional to the rate of change of the input signal. (a) Consider another circuit shown below.

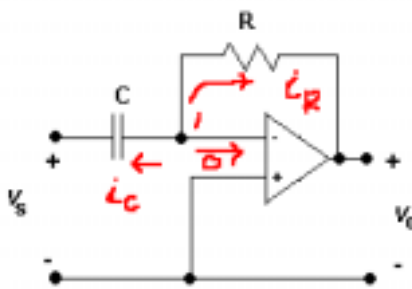

(b) Applying KCL at node 1:  $i_R + i_C = 0$   $i_R = \frac{0 - v_o}{R}$  and  $i_C = -C \frac{dv_s}{dt}$ .

(c) Therefore, we have:  $\frac{v_o}{R} = -C \frac{dv_s}{dt} \rightarrow v_o(t) = -RC \frac{dv_s(t)}{dt}$

(d) Caveat: Differentiator circuits are electronically unstable because any electrical noise within the circuit is exaggerated by the differentiator. Hence, the differentiator circuit is not as useful and popular as the integrator. It is seldom used in practice.